



# YOUR HANDY RECIPE PACK



[orbitcustomerhub.org.uk](http://orbitcustomerhub.org.uk)



# WELCOME

to your handy recipe pack

.....

We are all feeling the crunch as the cost of living continues to rise and are looking for ways to cut down on our food bill. Here's how you can reduce yours, starting this week. This pack offers a variety of recipes, catering to both individual meals and those suitable for the entire family. We have also included some tips and advice to help you make the most out of your food shop.

.....



## CONTENTS

### MEALS FOR ONE

The Great British Cheese Toastie.....	6
Thai Basil Chicken.....	8
Mac 'N' Cheese.....	10

### MEALS FOR TWO

Margherita Pizza .....	14
Easy Tomato Pasta .....	16
Spaghetti Bolognese.....	18

### MEALS FOR YOUR FAMILY

Chicken Fajitas .....	22
Creamy Bacon Pasta Salad.....	24
Shepherd's Pie.....	26

### SCRUMPTIOUS VEGAN MEALS

Vegan Chickpea Curry Jacket Potatoes.....	30
Vegan Chilli .....	32
Easy Vegan Pancakes.....	34

### HELP AND SUPPORT

Tips for saving costs on your food .....	38
Handy food apps .....	40





MEALS FOR

ONE





Approximate cost  
per portion:  
£1.65\*

### Ingredients

- 1 tablespoon salted butter
- 4 slices of your every day bread
- 2 ounces cheddar cheese
- Salt and pepper

### Method

#### Step one

Butter one side of each slice of bread. We don't recommend buttering both sides of the bread for a cheese toastie since it can make the sandwich a bit soggy.

#### Step two

Grate the cheddar cheese using a large hole grater (if you use a small hole the cheese will melt too quickly before the bread has toasted). Divide the cheese between 2 slices of bread, placing it on the unbuttered side. Season with a bit of salt and pepper to taste. Cover with the second slice of bread, buttered-side up.

#### Step three

Heat your griddle or frying pan to hot but not smoking. Using a flat spatula, lay the 2 sandwiches into the hot pan (they should sizzle a little as they hit the pan—if not, the pan is not hot enough). Gently press the sandwich with the spatula and do not worry if the cheese leaks a little. Cook for a few minutes on one side pressing from time to time, then flip it over and repeat on the other side. Remove from the pan once the cheese is starting to melt and the bread has turned a golden brown.

### Recipe variations

There are endless filling options in addition to the cheese:

- Thick-cut ham.
- Strips of cooked bacon.
- Thinly sliced mushrooms, onions, or tomatoes (or be adventurous and use all three).
- A thick smear of chutney or a spicy relish on the unbuttered side.
- Thinly sliced pickled onions sprinkled over the cheese.

P.S. this would go great with a side salad or some hearty soup!



# CHEESE TOASTIE

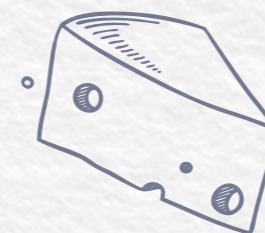

6



Approximate cost  
per portion:  
£2.35\*

Get adventurous with  
this weekend treat

# THAI BASIL CHICKEN

## Make it veggie!

If you would rather not add chicken to the dish, simply substitute for tofu, or extra veg (potato, chickpeas, sweet potato).

## Ingredients

- 2 tablespoons vegetable oil
- ½ onion, sliced
- 3 cloves garlic, sliced
- 1 large skinless, boneless chicken breast, cut into 1-inch pieces
- ¼ cup oyster sauce
- 3 tablespoons soy sauce
- 1 pinch of white sugar
- 2 small chilli peppers, sliced (optional)
- ⅓ cup water
- ½ cup of fresh basil leaves

## Method

### Step one

Heat oil in a wok or large skillet over medium heat. Add onion and garlic; cook and stir until fragrant, about 30 seconds.

### Step two

Add chicken; cook and stir until no longer pink, about 5 minutes. Stir in oyster sauce, soy sauce, and sugar. Stir in chilli peppers. Pour in water.

### Step three

Cook until slightly thickened, 3 to 5 minutes. Stir in basil before serving.



## Ingredients

- 75g/2¾oz dried pasta, preferably penne or macaroni
- 20g/¾oz butter
- 20g/¾oz plain flour
- 300ml/10fl oz milk
- 50g/1¾oz cheddar (preferably mature), finely grated
- Salt and ground black pepper
- Crusty bread, to serve (optional)



Approximate cost  
per portion:  
**£1.05\***

# MAC 'N' CHEESE

## Method

### Step one

Half-fill a large saucepan with water and cover with a lid. Place over a high heat and bring to the boil. Add the pasta, stir well and return to the boil. Cook without a lid for 10–12 minutes, or until the pasta is tender but retains a little 'bite', stirring occasionally so it doesn't stick.

### Step two

Meanwhile, place a medium saucepan (ideally non-stick) over a medium heat, add the butter and allow to melt. As soon as the butter has melted, sprinkle over the flour and stir well with a wooden spoon until it is completely mixed with the melted butter.

### Step three

Slowly start adding the milk, just a little at a time and stirring well between each addition.

(Adding the milk just 3 tablespoons at a time to begin with will help keep the sauce smooth). When you first add the milk, the flour mixture will seize up and look a little lumpy, but the more you stir, the smoother it will become. Continue gradually adding and stirring until all the milk is used up.

### Step four

Stir in roughly two-thirds of the cheese, a generous pinch of salt and 3–4 twists of black pepper (roughly ¼ tsp coarsely ground pepper). Simmer the sauce gently for 2–3 minutes, stirring constantly until it is thickened and glossy.

### Step five

Drain the pasta well in a colander or sieve and return to the pan. Pour the cheese sauce over the top and stir well. Either serve from the pan with the remaining grated cheese on top or transfer to an ovenproof dish and place under a hot grill for 1–2 minutes until lightly browned. Serve with the bread, if using.

Boost this dish with wholesome goodness by tossing in a mix of broccoli, peas, or sweetcorn.

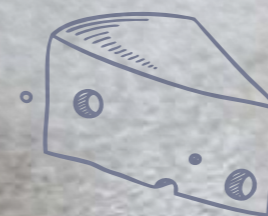

# 10





MEALS FOR

TWO



## Ingredients

- Olive oil, for the tray
- 200g plain flour
- 7g packet easy-blend dried yeast
- 1 tsp sugar
- 125ml warm water
- 85ml passata
- 100g mozzarella, half grated, half chopped
- 2 tbsp grated parmesan or vegetarian alternative
- Small bunch of basil, half chopped, half left whole
- Side salad, to serve

## Method

### Step one

Heat oven to 240C/220C fan/gas 9. Oil a 20 x 24cm baking tray. Mix the flour, yeast, ¼ tsp salt and the sugar in a bowl, then stir in the water. Bring the mixture together, knead until smooth, then press into the oiled tray.

### Step two

Spread passata over the dough, leaving a thin border round the edge. Season the passata, then sprinkle with the chopped basil, the mozzarella and the Parmesan, and bake for 15-20 minutes or until cooked through. Scatter with the remaining basil and serve with a side salad.

## Fancy mixing it up?

### Tikka pizza:

Scatter some cooked chicken tikka over the passata and replace the basil with coriander. For extra heat, add some chopped chilli too.

### Chorizo and olive pizza:

Layer thin slices of chorizo over the passata and scatter with sliced olives.

### How about a veggie fiesta:

Load up on a medley of peppers, mushrooms, onions, spinach, and anything else you fancy!

Approximate cost  
per portion:  
**£1.80\***

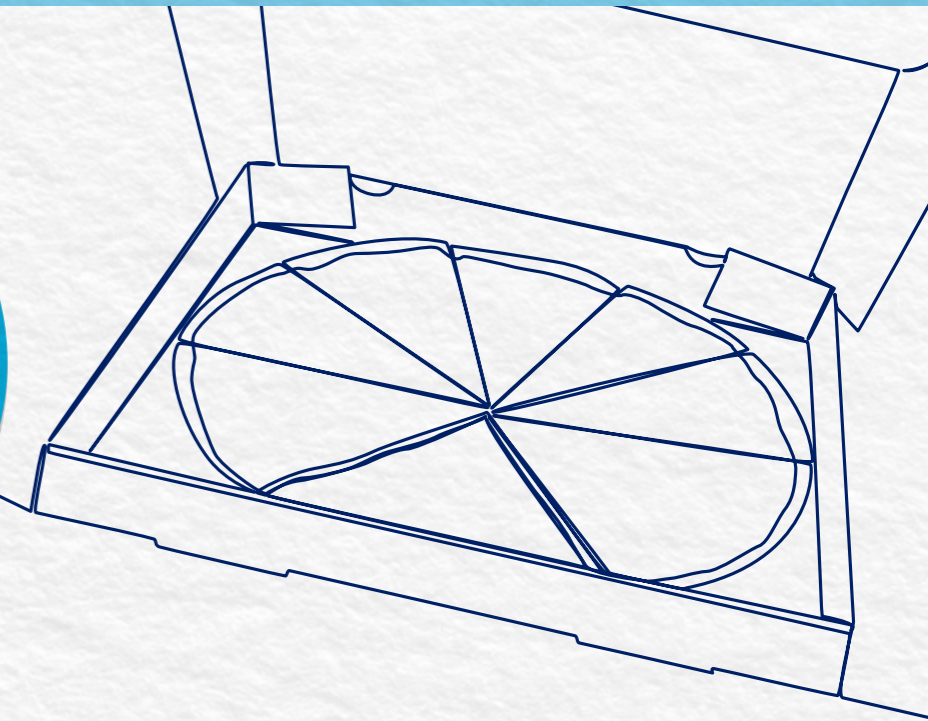

# MARGHERITA PIZZA

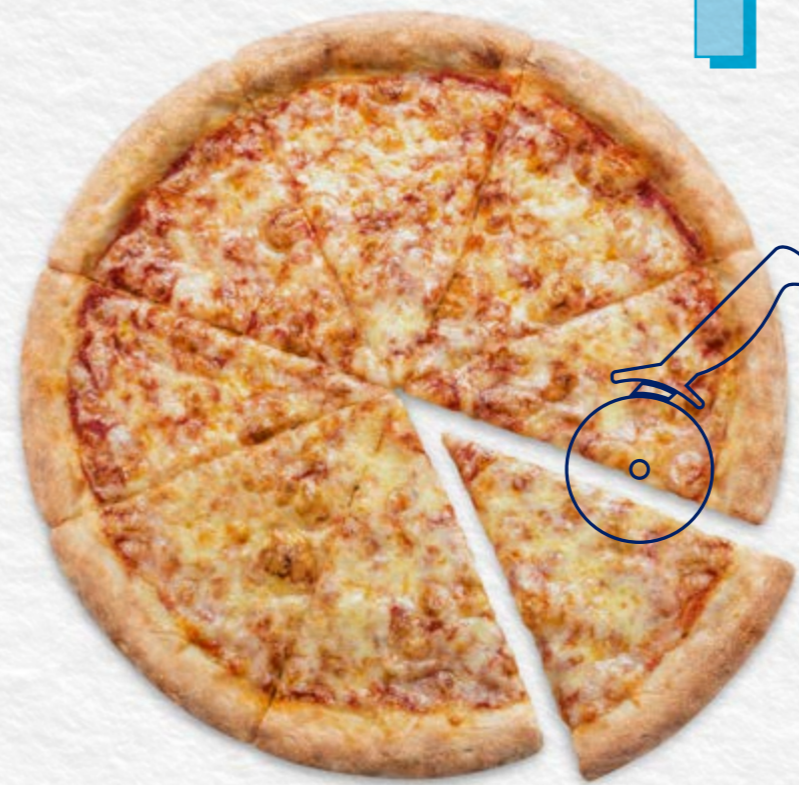
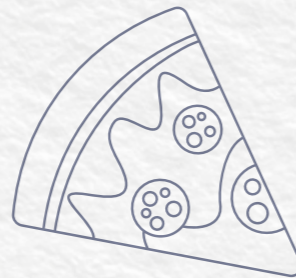





Approximate cost  
per portion:  
**£1.43\***

# Easy Tomato Pasta

## Ingredients

- 1 tbsp olive oil
- 1 onion, chopped
- 1 garlic clove, crushed
- 400g can cherry or chopped tomatoes
- Pinch of sugar
- A few dashes Worcestershire sauce
- 100g rigatoni or other tube-shaped pasta
- 50g of your favourite cheese, grated
- Hunk of baguette or sliced bread, coarsely grated



## Method

### Step one

Heat the oil in a medium pan and fry the onion for 5 minutes until softened and lightly golden. Stir in the garlic and cook for a further minute. Mix in the tomatoes and sugar, bring to the boil and simmer for 20 minutes. Add a few dashes of Worcestershire sauce and season to taste. This basic sauce can now be chilled or frozen.



### Step two

Meanwhile, cook the pasta according to pack instructions. Heat the grill to high. Mix together the cheese and breadcrumbs.

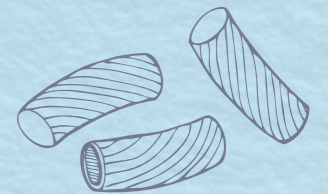

### Step three

Drain the pasta, stir into the sauce and spoon into a heatproof dish. Scatter over the cheesy crumbs and grill for 3-5 minutes or until bubbling hot and golden. Serve with a simple salad.

**Boost your dish with chicken, bacon, or sausage for added flavour and protein.**



## Ingredients

- 2 tbsp olive oil
- 400g/14oz beef mince
- 1 onion, diced
- 2 garlic cloves, chopped
- 100g/3½oz carrot, grated
- 2 x 400g tins chopped tomatoes
- 400ml/14fl oz stock (made from stock cube. Ideally beef, but any will do)
- 400g/14oz dried spaghetti
- Salt and pepper

# SPAGHETTI BOLOGNESE

Approximate cost  
per portion:  
**£1.43\***

## Method

### Step one

Heat a large saucepan over a medium heat. Add a tablespoon of olive oil and once hot add the beef mince and a pinch of salt and pepper. Cook the mince until well browned over a medium-high heat (be careful not to burn the mince. It just needs to be a dark brown colour). Once browned, transfer the mince to a bowl and set aside.

### Step two

Add another tablespoon of oil to the saucepan you browned the mince in and turn the heat to medium. Add the onions and a pinch of salt and fry gently for 5-6 minutes, or until softened and translucent. Add the garlic and cook for another 2 minutes. Add the grated carrot then pour the mince and any juices in the bowl back into the saucepan.

### Step three

Add the tomatoes to the pan and stir well to mix. Pour in the stock, bring to a simmer and then reduce the temperature to simmer gently for 45 minutes, or until the sauce is thick and rich. Taste and adjust the seasoning as necessary.

### Step four

When ready to cook the spaghetti, heat a large saucepan of water and add a pinch of salt. Cook according to the packet instructions. Once the spaghetti is cooked through, drain and add to the pan with the bolognese sauce. Mix well and serve.

### Tips:

- Fancy a veggie alternative? Simply replace the mincemeat with Quorn mince.
- Get freezing! This recipe can be frozen. So, pack up the extra portions for lunch or dinner that week.



MEALS FOR

# YOUR FAMILY





# Chicken Fajitas

## Ingredients

- 6 flour tortillas
- 2 chicken breasts, cut into strips
- 2 garlic cloves, finely chopped
- ½ tsp ground cumin
- 1 tsp chilli powder
- 1 lime, juice only
- 2 tbsp olive oil
- 1 red onion, thinly sliced
- 2 peppers, preferably different colours, thinly sliced
- Salt and pepper



## Method

### Step one

Heat the oven to 120C/100C Fan/Gas ½. Wrap the tortillas in kitchen foil, place on a baking tray and warm in the oven until ready to use.



### Step two

Put the chicken in a bowl with the garlic, cumin, chilli powder and lime juice. Season with salt and pepper and toss, rubbing the seasoning into the chicken. Set aside to marinate for 5 minutes.

### Step three

Heat 1 tablespoon of the oil in a frying pan over a high heat. Add the chicken strips and cook for 5 minutes, until cooked through, golden-brown and slightly catching on the edges.



### Step four

Add the remaining 1 tablespoon of oil to the pan, add the onion and peppers and fry for 5 minutes, or until almost soft. Increase the heat until the vegetables char slightly on the edges.

### Step five

To assemble the fajitas, top the warmed tortillas with the chicken and vegetable mix. Top with your chosen toppings.

Approximate cost  
per portion:  
**£2.00\***





# Creamy Bacon

# PASTA SALAD

## Ingredients

- 150g cooking bacon, meat finely sliced
- 250g fusili pasta
- 200g frozen green beans
- 125ml 50% less fat sour cream
- 1 small garlic clove, crushed
- ½ lemon, juiced
- 75g baby spinach, washed
- 1 cucumber portion, deseeded and sliced
- 4 spring onions, finely sliced

## Method

### Step one

Preheat the grill to high. Put the bacon on the grill tray and grill for 8-10 minutes, turning halfway, until very crisp and deep golden. Leave to cool slightly.

### Step two

Meanwhile, cook the pasta to pack instructions, adding the green beans for the last 3 minutes; drain.

### Step three

Mix the crème fraîche, garlic, lemon juice and some seasoning in a large bowl. Stir in the cooked pasta and green beans, the spinach, cucumber and spring onions; toss well to coat. Divide between plates or tip onto a platter. Crumble over the cooked bacon to serve.



Approximate cost  
per portion:  
£2.90\*





# SHEPHERD'S PIE



## Ingredients

- 1 tbsp olive oil or vegetable oil
- 1 onion finely chopped
- 2 carrots finely chopped or whizzed in a food processor until they form a paste
- 1 tbsp tomato puree
- 500g lamb mince
- 1 can chopped tomatoes
- Splash Worcestershire sauce
- 1 low salt beef stock cube
- 900g potatoes peeled and cut into small chunks
- 50g butter
- 5 tbsp milk

## Method

### Step one

Place potatoes in a pan and cover with boiling water from the kettle. Put on a medium heat to simmer for 18 to 20 minutes. They are ready when tender.

### Step two

Preheat oven to 170C (fan). Meanwhile fry the lamb mince in the olive oil over a high heat until browned all over. Reduce heat and add the onions and fry for 3 minutes.

### Step three

Add the carrot and cook for 2 minutes. Add the can of chopped tomatoes to the mince along with the stock cube. Half fill the empty can with water then pour this into the pan. Stir. Add the Worcestershire sauce and tomato puree then stir well and leave to simmer for 10 minutes. Drain the potatoes when they are ready.

Leave in the colander for a minute to allow steam to reduce a little.

### Step four

Put the potatoes back into the pan you boiled them in and add the butter and milk before mashing well. You could use a potato ricer if you choose.

### Step five

Put lamb mix into a pie dish. Divide some of the lamb mince between ramekins if making mini shepherd's pies for your kids. Top with mashed potato.

### Step six

Place the dish into the oven and cook for 30 minutes until potato has started to brown. Remove from oven and serve with peas!



Approximate cost  
per portion:  
**£1.98\***



# SCRUMPTIOUS VEGAN

MEALS





Vegan

# CHICKPEA CURRY JACKET POTATOES

Approximate cost  
per portion:  
**£1.41\***

## Ingredients

- Four sweet potatoes
- 1 tbsp coconut oil
- 1 ½ tsp cumin seeds
- One large onion, diced
- Two garlic cloves, peeled then crushed
- Thumb-sized piece ginger, finely grated
- One green chilli, finely chopped
- 1 tsp garam masala
- 1 tsp ground coriander
- ½ tsp turmeric
- 2 tbsp tikka masala paste
- Two x 400g can chopped tomatoes
- Two x 400g can chickpeas, drained
- Lemon wedges and coriander leaves, to serve

## Method

### Step one

Heat oven to 200C/180C fan/gas 6. Prick the sweet potatoes all over with a fork, then put on a baking tray and roast in the oven for 45 minutes or until tender when pierced with a knife.

### Step two

Meanwhile, melt the coconut oil in a large saucepan over medium heat. Add the cumin seeds and fry for one minute until fragrant, then add the onion and fry for seven to 10 minutes until softened.

### Step three

Put the garlic, ginger and green chilli into the pan, and cook for two to three minutes. Add the spices and tikka masala paste and cook for a further two minutes until fragrant, then tip in the tomatoes. Bring to a gentle simmer, then tip in the chickpeas and cook for a further 20 minutes until thickened. Season.

### Step four

Put the roasted sweet potatoes on four plates and cut open lengthways. Spoon over the chickpea curry and squeeze over the lemon wedges. Season, then scatter with coriander before serving.



30





Approximate cost  
per portion:  
**£1.44\***

# Vegan Chilli

## Ingredients

- 3 tbsp olive oil
- Two sweet potatoes, peeled and cut into medium chunks
- 2 tsp smoked paprika
- 2 tsp ground cumin
- One onion, chopped
- Two carrots, chopped
- Two celery sticks, chopped
- Two garlic cloves, peeled and crushed
- 1-2 tsp chilli powder (depending on how hot you like it)



- 1 tsp dried oregano
- 1 tbsp tomato purée
- 1 red pepper, cut into chunks
- Two x 400g cans chopped tomatoes
- 400g can black beans, drained
- 400g can kidney beans, drained
- Lime wedges, guacamole, rice and coriander to serve

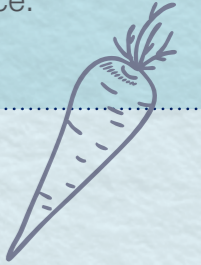

## Got leftovers?

This recipe is freezable. Why not bring it out another day and switch it up between serving with sweet potatoes, salad and/or rice.

## Method

### Step one

Heat the oven to 200c/180c fan/gas 6. Put the sweet potato in a roasting tin and drizzle over 1½ tbsp oil, 1 tsp smoked paprika and 1 tsp ground cumin. Give everything a good mix so that all the chunks are coated in spices, season with salt and pepper, then roast for 25 minutes until cooked.

### Step two

Meanwhile, heat the remaining oil in a large saucepan over a medium heat. Add the onion, carrot and celery. Cook for eight to 10 minutes, stirring occasionally until soft, then crush in the garlic and cook for one more minute. Add the remaining dried spices and tomato purée. Give everything a good mix and cook for another minute.

### Step three

Add the red pepper, chopped tomatoes and 200ml water. Bring the chilli to a gentle boil, then simmer for 20 minutes. Tip in the beans and cook for another 10 mins before adding the sweet potato. Season to taste then serve with lime wedges, guacamole, rice and coriander. It will keep in an airtight container in the freezer for up to three months.

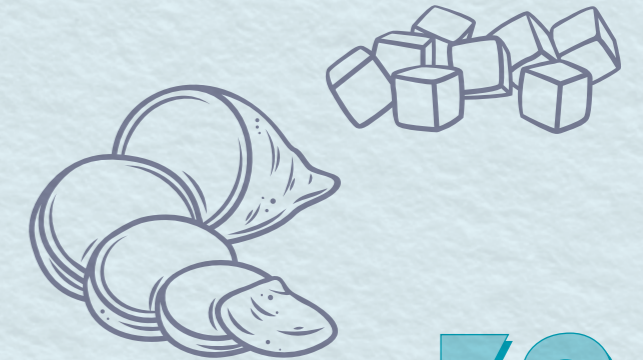



## Ingredients

- 300g self-raising flour
- 1 tsp baking powder
- 1 tbsp sugar (any kind)
- 1 tbsp vanilla extract
- 400ml plant-based milk (such as oat, almond or soya)
- 1 tbsp vegetable oil for cooking

## Method

### Step one

Whisk the flour, baking powder, sugar, vanilla extract and a pinch of salt in a bowl. Slowly pour in the milk until you get a smooth, thick batter.

### These pancakes are freezable!

Place a piece of baking parchment between each one to stop them sticking. Reheat in the microwave (or wrapped in foil in the oven if you don't have a microwave).

### Step two

Heat a little of the oil in a non-stick frying pan over a medium-low heat and add 2 tbsp batter into the pan at a time to make small, round pancakes. You will need to do this in batches of two-three at a time. Cook for three to four minutes until the edges are set and bubbles start to appear on the surface. Flip the pancakes over and cook for another two to three minutes until golden on both sides and cooked through. Keep warm in a low oven while you cook the remaining pancakes.

### Step three

Serve stacked with lots of toppings of your choice - or serve with bowls of toppings for everyone to help themselves.

### To serve (optional)

- Banana slices
- Blueberries
- Maple syrup
- Vegan chocolate chips
- Plant-based yogurt



Approximate cost  
per portion:  
£0.44p\*

Easy Vegan

# PANCAKES



# HELP AND SUPPORT





# TIPS

## for saving costs on your food

We've rounded up the best cost saving resources that we could find and put them all in one handy place. Make the most out of your trips to the supermarket or use your food wisely to reduce food waste.

### Get Planning

When it comes to food, you can always save a few pennies by simply becoming a little more organised when it comes to planning.

Sometimes it can be challenging going into a supermarket to buy exactly what you need. Sometimes we buy too much food and can be left with too much waste. Love Food Hate Waste has come up with a fantastic solution for this, their 'everyday portion planner'. This simple planner will help you buy just what you need and even assist you with the prep, cooking and serving amounts.

Start planning your meals better by visiting:  
[lovefoodhatewaste.com](http://lovefoodhatewaste.com)

### Cooking at home can save you money

Cooking at home is far less expensive than dining out or ordering takeaways. With a little know how, you can make great tasting meals and save on how much you spend on food.

One of the simplest ways to approach batch cooking is to make one base recipe which can be changed into different dishes. There's no need to eat the same thing all week – you can freeze in portions and enjoy them later. Shopping in bulk is also a proven method to save money on food, and batch cooking is a great way to take advantage of this whilst also reducing your energy bills too.

To find out more visit  
[dontwastethecrumbs.com/how-to-save-time-money-batch-cooking/](http://dontwastethecrumbs.com/how-to-save-time-money-batch-cooking/)

### Get chilled with frozen food

What can we freeze? Do we need to buy everything fresh? There are many questions when it comes to freezing our food, and by making a few changes and using your freezer space wisely, you can help save you on your food and electricity costs.

- Opt for frozen chopped vegetables and fruit for a cost-effective option with identical nutritional benefits. Minimize wastage and easily customize your portions to suit your preferences.
- Make the most of your freezer by exploring the wide range of foods that you can freeze. Love Food Hate Waste shares seven foods that you can surprisingly freeze.
- Love Food Hate Waste has provided a great list of fresh foods you can swap for frozen. No need to worry about when that best before date comes closer anymore.

Learn more about swapping fresh food for frozen in this handy guide.  
[lovefoodhatewaste.com](http://lovefoodhatewaste.com)

### Get savvy with discounts in the supermarkets

Not making the use of supermarket loyalty cards or coupons can be a real missed opportunity. This Martin Lewis page shows you how to do couponing the right way and you can walk away with food, toiletries and more for free or a fraction of the normal cost.

This guide will help you navigate this new couponing world.  
[moneysavingexpert.com/deals/supermarket-coupons/](http://moneysavingexpert.com/deals/supermarket-coupons/)

### The Trussel Trust

You can get a referral from social agencies for vouchers if you need free, emergency food. These can be exchanged for a parcel with three days of nutritionally balanced food. They can include store cupboard ingredients such as pasta, cereal, tinned vegetables and long-life milk etc. Fresh food is also offered when available. Most food banks also offer toiletries, pet food, cleaning and baby products too.

### Community fridges

This is where extra food is shared for free, bringing people together to eat, connect, learn new skills and reduce food waste. They are usually stocked by local businesses sharing food that wouldn't otherwise be sold in time, fresh produce from local gardeners and food provided by the public.

To find out more visit:

[hubbub.org.uk/the-community-fridge](http://hubbub.org.uk/the-community-fridge)

### Gurdwaras

All Sikh temples, also known as Gurdwaras, offer free vegetarian meals to people of all backgrounds via a 'langar'. In Sikhism, 'langar' means a community kitchen run by volunteers.

Just search '**Gurdwaras near me**' to find your local community kitchen.

You can search your local foodbank here:  
[trusselltrust.org/get-help/find-a-foodbank](http://trusselltrust.org/get-help/find-a-foodbank)

# 38



Handy

# FOOD APPS

There are numerous apps around that we can download which will help cut costs on food, but knowing which ones are worth it can be a struggle.

To help make it a bit easier, we've rounded up the best food apps to help you make your pounds stretch a little bit further and they're all in one handy place.

## Too Good to Go

This app is a firm favourite for budget-friendly meals, helping you enjoy your preferred foods without overspending. Another selling point of this app is that it helps reduce food waste. So rather than throwing away perfectly fine excess food at the end of the day, customers can pick this up at heavily reduced prices! Great for both consumer and company. A whole host of companies take part, including Starbucks, Greggs, Toby Carvery and Costa to name a few.

Search '**Too Good to Go**' on your app store.



## Olio

Similar to Too Good to Go, Olio is another great app for food waste. You can search in your local area for food which is being given away for no cost whatsoever.

Both individuals and stores can take part too. This could be excess food or something which has passed its best before date.

If you find yourself with food that you no longer want, you can offer it up to others. Best of all, it's completely free to use.

Search '**Olio**' on your app store.

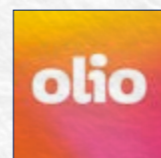

To check out even more ways to save money on your food via your phone visit: [orbitcustomerhub.org.uk/news/articles/foodapps/](https://orbitcustomerhub.org.uk/news/articles/foodapps/)

## Karma

The Karma app allows customers to purchase fresh food from local businesses and supermarkets which would have otherwise been thrown away. Like 'Too Good to Go' and 'Olio', Karma is another great app to have on your phone to get your favourite food, but for a greatly reduced price!

What's more, it's absolutely free to download. You pay for your discounted products over the app and then collect them from the store.

Search '**Karma**' on your app store.

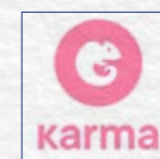

## Out of Milk

This one is a must. The Out of Milk app provides you with pre-made grocery list templates for all occasions. The app also helps you keep track of what you've bought, what you still need to pick up and adds them all back onto a list for your next shop. It's received over 150,000 five-star reviews, so it's worth a download.

Search '**Out of Milk**' on your app store.



# 40



## Need extra help or support?

Our free Better Days programme offers expert advice and practical information across a wide-range of support services from mental health, financial or debt advice, to employment and digital skills. Simply go to [orbitcustomerhub.org.uk/costofliving](https://orbitcustomerhub.org.uk/costofliving) to find out more. You can also call us on 0800 678 1221.

**BETTERDAYS**<sup>®</sup>  
have a good day, every day

# GET IN TOUCH:

You can visit our website:

**[orbitcustomerhub.org.uk](https://orbitcustomerhub.org.uk)**

For more information,  
please contact us at:

**[orbitcustomerhub.org.uk/contact-us](https://orbitcustomerhub.org.uk/contact-us)**

Or to talk to us, please call:

**0800 678 1221**

Textphone:

**18001 0800 678 1221**

Take a look on social media:

**f /OrbitHelp**

**X @OrbitHelp**

Our postal address:

**Orbit  
PO Box 6406  
Coventry  
CV3 9NB**

If you need this information  
in a different format,  
please contact us on  
**0800 678 1221**

Orbit Group Ltd and Orbit Housing Association Ltd are registered societies under the Co-operative and Community Benefit Societies Act 2014 and are exempt charities registered with the Regulator of Social Housing.



February 2024